

**Fast CMOS Octal D Flip-Flop
with Clock Enable**
Product Features:

- The PI74FCT377T is pin compatible with bipolar FAST™ Series at a higher speed and lower power consumption
- TTL input and output levels
- Octal D flip-flops with Clock Enable
- Extremely low static power
- Hysteresis on all inputs
- Industrial operating temperature range: -40°C to +85°C
- Packages available:
 - 20-pin 173 mil wide plastic TSSOP (L)
 - 20-pin 300 mil wide plastic DIP (P)
 - 20-pin 150 mil wide plastic QSOP (Q)
 - 20-pin 150 mil wide plastic TQSOP (R)
 - 20-pin 300 mil wide plastic SOIC (S)

Product Description:

Pericom Semiconductor's PI74FCT series of logic circuits are produced in the Company's advanced 0.6/0.8 micron CMOS technology, achieving industry leading speed grades.

The PI74FCT377T is an 8-bit wide octal designed with eight edge-triggered D-type flip-flops with individual D inputs and O outputs. When Clock Enable (CE) is LOW, the common buffered Clock (CP) loads all flip-flops simultaneously. The register is fully edge-triggered. D input state, one setup time before the LOW-to-HIGH clock transition, is transferred to the corresponding flip-flop's O output. The CE input must be stable only one setup time prior to the LOW-to-HIGH transition for predictable operation.

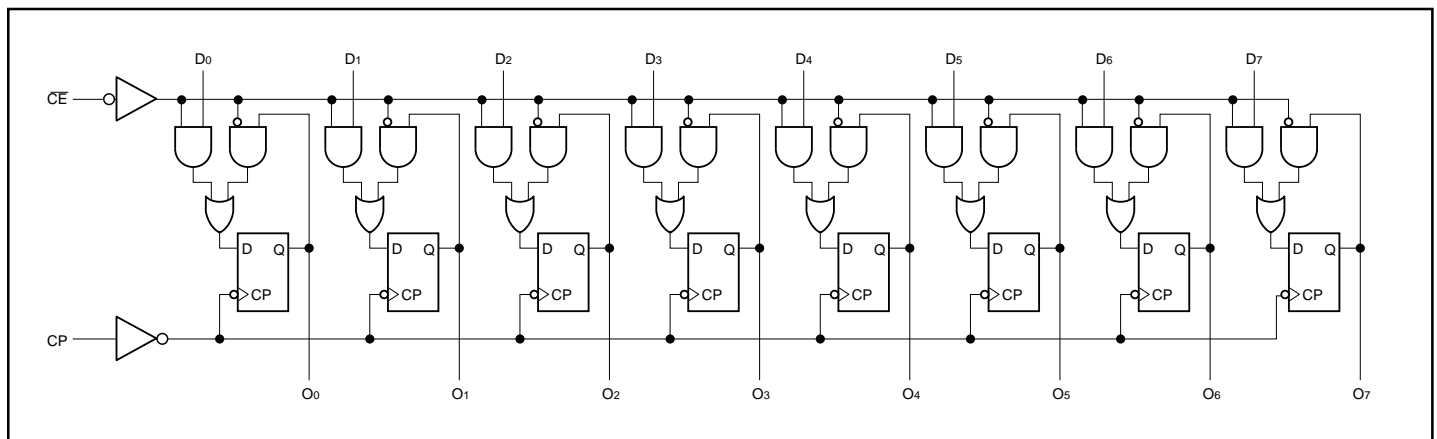
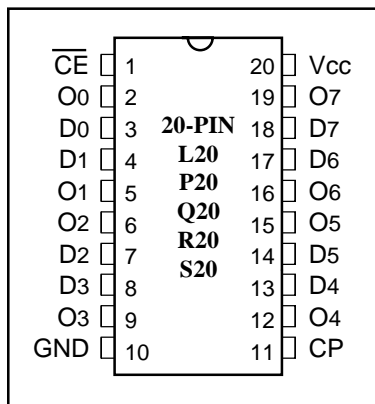
Logic Block Diagram

Product Pin Configuration

Product Pin Description

Pin Name	Description
CE	Clock Enable (Active LOW)
CP	Clock Pulse Input
D0-D7	Data Inputs
O0-O7	Data Outputs
GND	Ground
Vcc	Power

Truth Table⁽¹⁾

Mode	Inputs			Outputs
	CP	CE	DN	ON
Load "1"	↑	1	h	H
Load "0"	↑	1	l	L
Hold	↑	h	X	NC
(Do Nothing)	H	H	X	NC

1. H = HIGH Voltage Level
h = HIGH Voltage Level one setup time prior to the LOW-to-HIGH Clock Transition
L = LOW Voltage Level
l = LOW Voltage Level one setup time prior to the LOW-to-HIGH Clock Transition
X = Don't Care
NC = No Change
↑ = LOW-to-HIGH Clock Transition

Maximum Ratings

(Above which the useful life may be impaired. For user guidelines, not tested.)

Storage Temperature	-65°C to +150°C
Ambient Temperature with Power Applied	-40°C to +85°C
Supply Voltage to Ground Potential (Inputs & V _{CC} Only)	-0.5V to +7.0V
Supply Voltage to Ground Potential (Outputs & D/O Only)	-0.5V to +7.0V
DC Input Voltage	-0.5V to +7.0V
DC Output Current	120mA
Power Dissipation	0.5W

Note:

Stresses greater than those listed under MAXIMUM RATINGS may cause permanent damage to the device. This is a stress rating only and functional operation of the device at these or any other conditions above those indicated in the operational sections of this specification is not implied. Exposure to absolute maximum rating conditions for extended periods may affect reliability.

DC Electrical Characteristics (Over the Operating Range, T_A = -40°C to +85°C, V_{CC} = 5V ± 5%)

Parameters	Description	Test Conditions ⁽¹⁾		Min.	Typ ⁽²⁾	Max.	Units
V _{OH}	Output HIGH Voltage	V _{CC} = Min., V _{IN} = V _{IH} or V _{IL}	I _{OH} = -15.0 mA	2.4	3.0		V
V _{OL}	Output LOW Current	V _{CC} = Min., V _{IN} = V _{IH} or V _{IL}	I _{OL} = 64 mA		0.3	0.55	V
V _{IH}	Input HIGH Voltage	Guaranteed Logic HIGH Level		2.0			V
V _{IL}	Input LOW Voltage	Guaranteed Logic LOW Level				0.8	V
I _{IH}	Input HIGH Current	V _{CC} = Max.	V _{IN} = V _{CC}			1	μA
I _{IL}	Input LOW Current	V _{CC} = Max.	V _{IN} = GND			-1	μA
V _{IK}	Clamp Diode Voltage	V _{CC} = Min., I _{IN} = -18 mA			-0.7	-1.2	V
I _{OS}	Short Circuit Current	V _{CC} = Max. ⁽³⁾ , V _{OUT} = GND		-60	-120		mA
I _{OFF}	Power Down Disable	V _{CC} = GND, V _{OUT} = 4.5V		—	—	100	μA
V _H	Input Hysteresis				200		mV

Capacitance (T_A = 25°C, f = 1 MHz)

Parameters ⁽⁴⁾	Description	Test Conditions	Typ	Max.	Units
C _{IN}	Input Capacitance	V _{IN} = 0V	6	10	pF
C _{OUT}	Output Capacitance	V _{OUT} = 0V	8	12	pF

Notes:

1. For Max. or Min. conditions, use appropriate value specified under Electrical Characteristics for the applicable device type.
2. Typical values are at V_{CC} = 5.0V, +25°C ambient and maximum loading.
3. Not more than one output should be shorted at one time. Duration of the test should not exceed one second.
4. This parameter is determined by device characterization but is not production tested.

Power Supply Characteristics

Parameters	Description	Test Conditions ⁽¹⁾		Min.	Typ ⁽²⁾	Max.	Units
I _{CC}	Quiescent Power Supply Current	V _{CC} = Max.	V _{IN} = GND or V _{CC}		0.1	500	μA
ΔI _{CC}	Supply Current per Input @ TTL HIGH	V _{CC} = Max.	V _{IN} = 3.4V ⁽³⁾		0.5	2.0	mA
I _{CCD}	Supply Current per Input per MHz ⁽⁴⁾	V _{CC} = Max., Outputs Open CE = GND One Input Toggling 50% Duty Cycle	V _{IN} = V _{CC} V _{IN} = GND		0.15	0.25	mA/MHz
I _C	Total Power Supply Current ⁽⁶⁾	V _{CC} = Max., Outputs Open f _{CP} = 10 MHz, 50% Duty Cycle CE = GND 50% Duty Cycle One Bit toggling at f _I = 5 MHz	V _{IN} = V _{CC} V _{IN} = GND		1.57	3.5 ⁽⁵⁾	mA
			V _{IN} = 3.4V V _{IN} = GND		2.0	5.5 ⁽⁵⁾	
		V _{CC} = Max., Outputs Open f _{CP} = 10 MHz, 50% Duty Cycle CE = GND Eight Bits toggling at f _I = 2.5 MHz 50% Duty Cycle	V _{IN} = V _{CC} V _{IN} = GND		3.8	7.3 ⁽⁵⁾	
			V _{IN} = 3.4V V _{IN} = GND		6.0	16.3 ⁽⁵⁾	

Notes:

- For conditions shown as Max. or Min., use appropriate value specified under Electrical Characteristics for the applicable device.
- Typical values are at V_{CC} = 5.0V, +25°C ambient.
- Per TTL driven input (V_{IN} = 3.4V); all other inputs at V_{CC} or GND.
- This parameter is not directly testable, but is derived for use in Total Power Supply Calculations.
- Values for these conditions are examples of the I_{CC} formula. These limits are guaranteed but not tested.
- I_C = I_{QUIESCENT} + I_{INPUTS} + I_{DYNAMIC}
 $I_C = I_{CC} + \Delta I_{CC} D_{HNT} + I_{CCD} (f_{CP}/2 + f_I N_I)$
 I_{CC} = Quiescent Current
 ΔI_{CC} = Power Supply Current for a TTL High Input (V_{IN} = 3.4V)
 D_H = Duty Cycle for TTL Inputs High
 N_T = Number of TTL Inputs at D_H
 I_{CCD} = Dynamic Current Caused by an Input Transition Pair (HLH or LHL)
 f_{CP} = Clock Frequency for Register Devices (Zero for Non-Register Devices)
 f_I = Input Frequency
 N_I = Number of Inputs at f_I (All currents are in milliamps and all frequencies are in megahertz.)

Switching Characteristics over Operating Range

Parameters	Description	Conditions ⁽¹⁾	377T		377AT		377CT		377DT		Unit	
			Com.		Com.		Com.		Com.			
			Min	Max	Min	Max	Min	Max	Min	Max		
t _{PLH}	Propagation Delay	C _L = 50 pF R _L = 500Ω	2.0	13.0	2.0	7.2	2.0	5.2	2.0	4.5	ns	
t _{PHL}	CP to ON											
t _{SU}	Setup Time, HIGH or LOW D _n to CP		2.5	—	2.0	—	2.0	—	2.0	—	ns	
t _H	Hold Time, HIGH or LOW D _n to CP		2.0	—	1.5	—	1.5	—	1.5	—	ns	
t _{SU}	Setup Time HIGH or LOW CE to CP		4.0	—	3.5	—	3.5	—	2.0	—	ns	
t _H	Hold Time HIGH or LOW CE to CP		1.5	—	1.5	—	1.5	—	1.5	—	ns	
t _W	Clock Pulse Width ⁽³⁾ HIGH or LOW			7.0	—	6.0	—	6.0	—	3.0	—	ns

Notes:

- See test circuit and wave forms.
- Minimum limits are guaranteed but not tested on Propagation Delays.
- This parameter guaranteed but not production tested.